

VACALL™ RECYCLER

GREEN
THAT WORKS

Jet sewer lines clear all day long without a drop of city water

There's no need to load up city water to start work, or to stop several times a day for refills. In fact, the Vacall Recycler continuous water recycling system typically uses no city water at all for jetting.

Instead, the Recycler system vacuums existing water from sewer lines, filters the water in a five-step process and then re-uses the same water in the AllJetVac's high-powered jetting process.

An exclusive option for AllJetVac combination sewer cleaners, Vacall Recycler systems save time, money and the environment.

- Automatic, continuous filtering
- Increase productivity
- No filter change
- No back flushing after typical cleanout work
- No need for city water
- No need to stop work and drive to refill water tank
- Lower truck fuel consumption with less truck weight
- Minimal overall maintenance
- Low energy consumption
- High throughput rate
- Separate 240-gallon tank and pump for wash down

The Vacall Recycler system also includes a 240-gallon segregated clean water tank section attached to a 10 gpm pump and 50' hose reel for wash down.

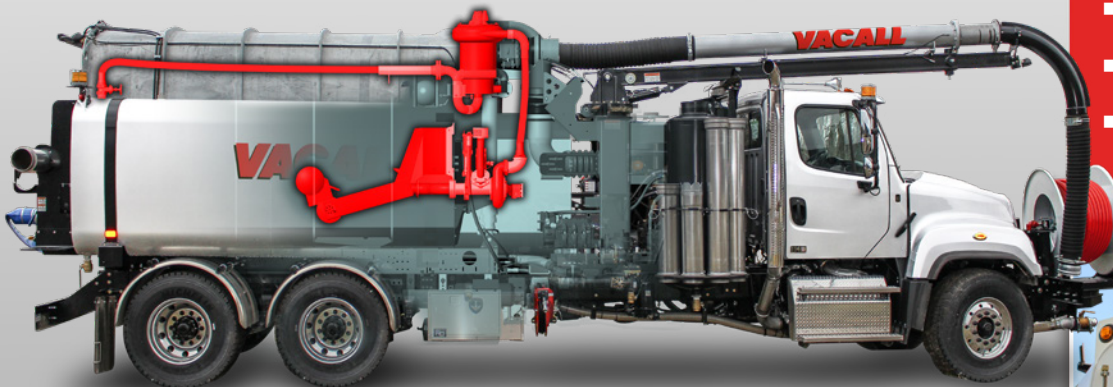
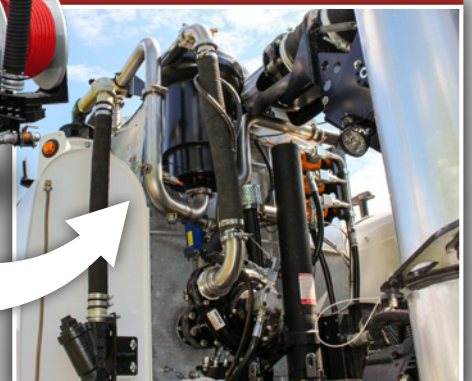

VACALL™ RECYCLER

SAVE MILLIONS OF GALLONS OF CITY WATER EACH YEAR

One AllJetVac combination sewer cleaning truck can save an average of 5.7 million gallons of city water each year when it's equipped with a Vacall Recycler continuous water recycling system, designed to use no city water. The water savings calculation is based on typical municipality usage statistics – using 80 gallons of water per minute, six hours per day and 40 weeks per year. Individual city water savings may vary, based on jetting activity.

Designed for exceptional reliability and durability, the entire Vacall Recycler unit is located at the front of the AllJetVac debris body – away from rocks, stones or incidental contact with other vehicles.

GREEN THAT WORKS

- ✓ Vacall Recycler system filters and re-uses existing water in sewer line
- ✓ Control water usage and power with standard Vacall AllSmartFlow™ controls
- ✓ Single-engine machine saves fuel, maintenance and cost
- ✓ Lifetime warranties on standard and optional water and debris tanks

HOW IT WORKS

- 1 Vacuumed from sewer lines, water undergoes an initial sediment separation.
- 2 Floating V-Filtration screen, with back-flush self-cleaning capability, filters water.
- 3 Water moves through high-speed centrifugal action process to remove remaining tiny particles as small as 100 microns.
- 4 Solids and fine particles are moved to the debris tank via pressure regulating valve system.
- 5 Filtered water moves into tank for jetting.

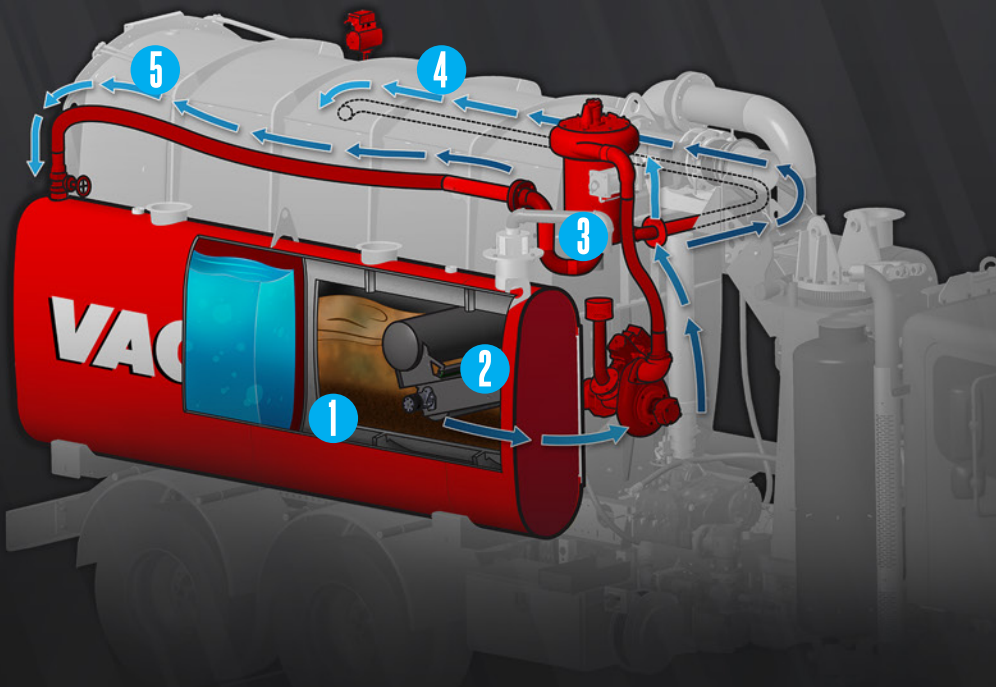

VACALL™

Gradall Industries LLC • 406 Mill Ave. SW, New Philadelphia, OH 44663

800-382-8302 • www.vacall.com

Form No. 11631 1/24
Printed in USA

Designs, materials and specifications are subject to change without notice and without incurring any liability on units already sold. Some machine photos may show options.



GRADALL
INDUSTRIES
Where Ingenuity Works